

SUNDAB

A mobile reclinable shower- and bathtub for people who has difficulties to use an ordinary bathtub.

Step in :

- As a shower, the SUNDAB provides low threshold front access. Its contoured shape and grab handle provide additional safety and comfort.



Shower :

- Sit down on the integrated seat and shower.
- Easy to reach the mixer and the shower handle.



Bath with safety:

- Fill with water which covers all your body.
- You remain seated while you are in the bath without the risk of 'slippage'.

Sundab AB, Gjuterigatan 7, 341 31 Ljungby. Tel & fax : 0372-84040.
e-mail : sundab@telia.com. Website : www.sundab.se



*Swedish product
Distributed all over Europe*

SUNDAB
Mobile and incliable

Including accessories :

- pressure balanced mixing valve
- flexible hose with shower handle
- grab handle
- external hoses
- electric charger (220V)
- hand control
- anti slip mat
- neck pillow
- manual

*Patented and
CE-approved*

Optional :

- integrated air-bubble bath
- height adjustable

Simple installation :

- connect hot- and cold water (min 3 bar)
- put the outlet hose on the floor to the drain
- connect the rechargeable accumulator

Technical specification :

- electric tilt function with rechargeable accumulator (24 V)
- the bathtub is made of glass reinforced plastic with a surface of sanitary gelcoat
- color: white
- total weight: 65kg
- safe working load: 150 kg (23 st).
- volume of water for a bath: 125 liters.
- total length (bath position): 1800 mm.
- height (bath position): 810 mm.
- total width: 750 mm.

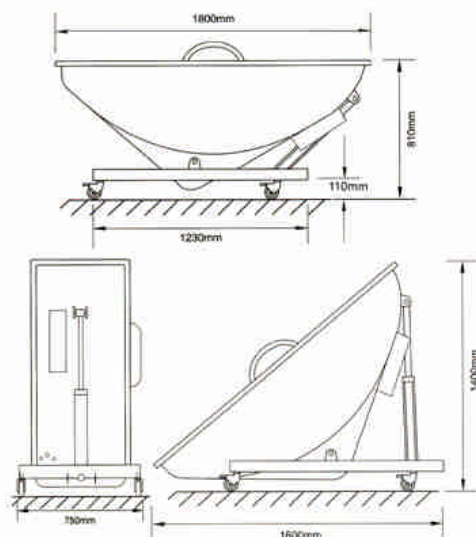

Security :

- ergonomic for user and assistant
- recline gently
- you can stop in all positions
- integrated seat prevents from slipping down
- developed in collaboration with nursing homes
- it is possible for the user to bath themselves
- all manoeuvres within a convenient reach
- easy to move on its castors